



THE CITY OF MARION HISTORIC DOWNTOWN STREETSCAPE PLAN

DIRECTIONAL SIGNAGE

**PREPARED BY:
CITY OF MARION PLANNING AND DEVELOPMENT DEPARTMENT
DECEMBER 2010**

HIGHWAY & INTERSTATE DESTINATION SIGNAGE

Interstate 40 & Highway 221
Sign Type A

These signs serve as a visitor's first impression of Marion, and are visible to a much broader audience due to their location along major interstates and highways. When asked, many visitors don't know that It is recommended that the City of Marion highlight

Interstate & Highway Proposed Design



NC DOT Model for Proposed Destination Signage

Section 2E.32 Other Supplemental Guide Signs

Guidance:

Use of Supplemental guide signs should be limited; however, if more than two supplemental signs are required, combining supplemental sign messages onto one sign should be considered, such as in the following example:



Example: Existing Interstate 40 Sign



WAYFINDING SIGNAGE

SIGN DETAIL

Notes:

1. Breakaway or yielding supports to meet NC DOT minimum standards.
2. Minimum 18 ft. from edge of travel lane.
3. Grade information (s-dimensions) with support design request needed.
4. National Register of Historic Places logo if possible
5. Posted speed limit is > than 55 mph therefore minimum 8 in lettering requested.
6. Max of 2 U channel post shall be used per install per NC DOT requirements. (NC Roadway Standard Drawing No. 909.30(S), Sheets 1 & 2)
7. Manual on Uniform Traffic Control Devices (MUTCD) and 2004 NC Supplement Chapter 2E Guide Freeway & Expressway Standards utilized for the proposed design.

HIGHWAY & INTERSTATE SIGNS

Interstate 40
& Highway 221
Destination Signage
Sign Type A

These signs serve as a visitor's first impression of Marion, and are visible to a much broader audience due to their location along major interstates and highways. When asked, many visitors don't know that It is recommended that the City of Marion highlight

Typical Sign Face Dimensions For Proposed Signage*

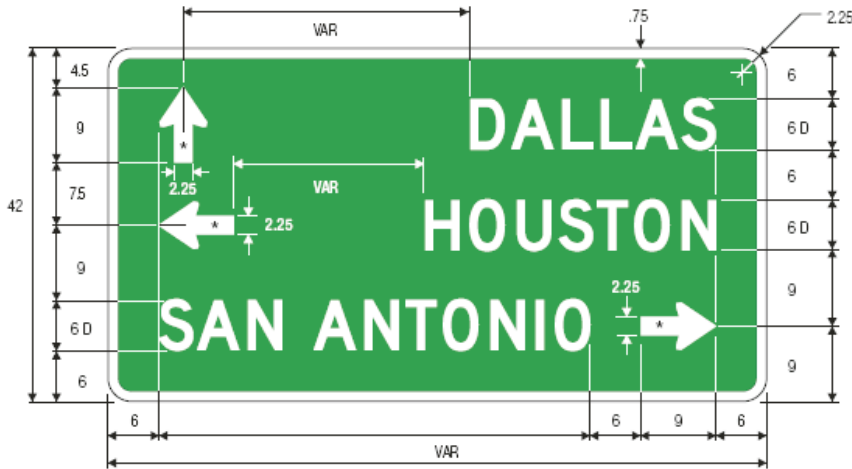

D1-3
DESTINATION

*See page 6-2 for arrow design.

*See Notes for proposed lettering dimensions.

Source: 2004 US DOT Federal Highway Administration Standard Highway Signs

Proposed Sign Traveling on Interstate 40
Exit 86 and Exit 81
Proposed Locations: Mile Marker #



Proposed Sign Traveling North
& South on Hwy 221 Bypass
Proposed Location: Mile Marker #



WAYFINDING SIGNAGE

SIGN DETAIL

Notes:

1. Breakaway or yielding supports to meet NC DOT minimum standards.
2. Minimum 18 ft. from edge of travel lane.
3. Grade information (s-dimensions) with support design request needed.
4. National Register of Historic Places logo if possible
5. Posted speed limit is > than 55 mph therefore minimum 8 in lettering requested.
6. Max of 2 U channel post shall be used per install per NC DOT requirements. (NC Roadway Standard Drawing No. 909.30(S), Sheets 1 & 2)
7. Manual on Uniform Traffic Control Devices (MUTCD) and 2004 NC Supplement Chapter 2E Guide Freeway & Expressway Standards utilized for the proposed design.

Town Limit Signage

Sign Type B

These signs serve to notify motorists that they are entering the city limits, which is under the control of the municipal government. It is customary to indicate city limits on major highways and arterial roads. The City of Marion has existing signs installed on all major arterial routes. Many communities utilize the standard DOT green and white signs to identify their municipal limits as provided in the example below. As part of the wayfinding signage program, this plan recommends that the existing signs be replaced with the standard highway sign.

In addition to these changes, the City should consider additional information that provides some factual data about the community. Common information that is included on this type of signage includes elevation and population data. The example shown below includes elevation and geographic coordinates. The purpose of providing this information is two-fold. First, unlike population, elevation and geographic coordinates do not change. Therefore, there is no maintenance associated with updating information as it changes. Second, with advancements in technology, many people use geographic coordinate data for many different purposes making it desirable information to post.



WAYFINDING SIGNAGE

SIGN DETAIL

CAUTION! CONSISTENT AND ACCURATE COLOR REPRODUCTION IN THIS DOCUMENT CANNOT BE ASSURE DUE TO THE LIMITATIONS OF COLOR PRINTING TECHNOLOGY.

The Coated Patone Matching System is used for specifying signage color matches. (In the absence of actual sign material color chip reference set, actual specified product color swatches should be referenced for color matching.) Shown here are approximations of the primary signage background colors and supporting accent colors.

Actual color finishes on signage are to be matte or low luster (not shiny or glossy).

Fabricator is responsible for matching all colors and materials as indicated and is required to provide color and material samples for approval.

Gateway Signs

“Welcome To Marion” Sign Type C

These signs were installed in 2006 replacing the older welcome signs located along major throughfares leading into the City. These signs are made of painted 10mm AlumCorr material, some of the signs include ornamental landscaping to add visual interest. No design changes are recommended to these signs. However, it is recommended that the City lower the existing signs to be more in line with vehicular line of sight and additional ornamental landscaping be incorporated around signs to enhance their visual appearance.

Location Sugar Hill Road



Location Highway 70 West



Location Intersection of Highway 221 & Highway 226



Location Highway 221 North



WAYFINDING SIGNAGE

SIGN DETAIL

CAUTION! CONSISTENT AND ACCURATE COLOR REPRODUCTION IN THIS DOCUMENT CANNOT BE ASSURE DUE TO THE LIMITATIONS OF COLOR PRINTING TECHNOLOGY.

The Coated Patone Matching System is used for specifying signage color matches. (In the absence of actual sign material color chip reference set, actual specified product color swatches should be referenced for color matching.) Shown here are approximations of the primary signage background colors and supporting accent colors.

Actual color finishes on signage are to be matte or low luster (not shiny or glossy).

Fabricator is responsible for matching all colors and materials as indicated and is required to provide color and material samples for approval.

Gateway Signs

“Welcome to Historic Downtown Marion” Sign Type D

These gateway signs serve to welcome visitors and alert them that they are entering historic downtown Marion. The sign structure allows for the continued use of the 4’x4’ community event signs and brackets for hanging baskets to add aesthetic appeal. There are three priority locations for these sign, which include:

- West Henderson Street
- Main Street and Morgan Street
- Main Street and Logan Street

Two additional locations are recommended as adequate public right-of-way is identified to accommodate the sign. These locations include East Court Street and West Court Street leading into downtown.

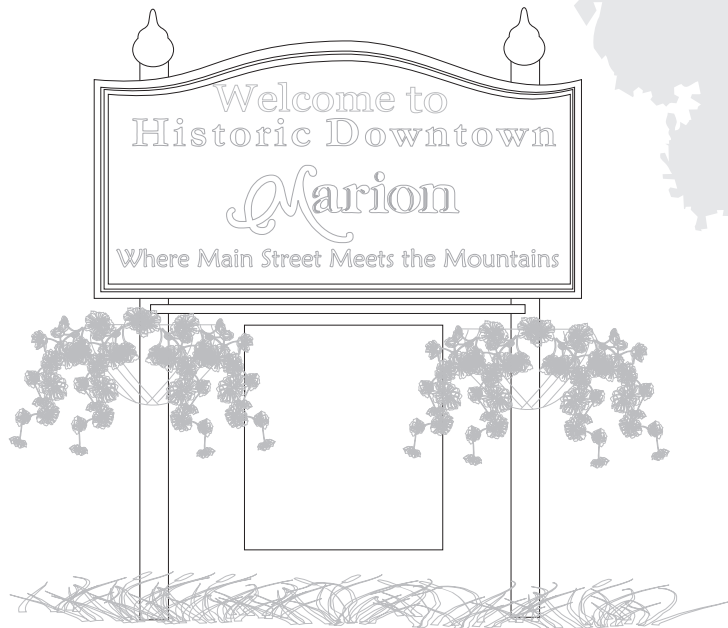

WAYFINDING SIGNAGE

SIGN DETAIL

CAUTION! CONSISTENT AND ACCURATE COLOR REPRODUCTION IN THIS DOCUMENT CANNOT BE ASSURE DUE TO THE LIMITATIONS OF COLOR PRINTING TECHNOLOGY.

The Coated Patone Matching System is used for specifying signage color matches. (In the absence of actual sign material color chip reference set, actual specified product color swatches should be referenced for color matching.) Shown here are approximations of the primary signage background colors and supporting accent colors.

Actual color finishes on signage are to be matte or low luster (not shiny or glossy).

Fabricator is responsible for matching all colors and materials as indicated and is required to provide color and material samples for approval.

Directional Signage

These signs would be incorporated into the downtown streetscape to direct motorists to destinations within the downtown area. Fifteen (15) directional signs are recommended to direct visitors to the downtown area and orient visitors to primary and secondary destinations. The following list identifies the destinations to be included on each individual sign as well as the proposed design of the directional sign.

- | | |
|---|---|
| <p>Northbound</p> <ol style="list-style-type: none"> 1. Main St. and West Henderson <ul style="list-style-type: none"> <input type="checkbox"/> City Hall <input type="checkbox"/> Courthouse <input type="checkbox"/> MACA <input type="checkbox"/> Farmer's Market <input type="checkbox"/> Marion Depot <input type="checkbox"/> Public Parking 2. Main St and Court <ul style="list-style-type: none"> <input type="checkbox"/> City Hall <input type="checkbox"/> Community Building <input type="checkbox"/> Public Parking <input type="checkbox"/> Visitor Center 3. Main St. New St <ul style="list-style-type: none"> <input type="checkbox"/> City Hall <input type="checkbox"/> Community Building <p>Southbound</p> <ol style="list-style-type: none"> 4. Main St and Logan <ul style="list-style-type: none"> <input type="checkbox"/> City Hall <input type="checkbox"/> Courthouse <input type="checkbox"/> Police Dept <input type="checkbox"/> Marion Depot <input type="checkbox"/> Fire Dept. <input type="checkbox"/> Visitor Center 5. Main St and Court <ul style="list-style-type: none"> <input type="checkbox"/> MACA <input type="checkbox"/> Police Dept. <input type="checkbox"/> Post Office <input type="checkbox"/> Library <input type="checkbox"/> Farmer's Market <input type="checkbox"/> Visitor Center 6. Main St and Henderson <ul style="list-style-type: none"> <input type="checkbox"/> Police Dept <input type="checkbox"/> Post Office <input type="checkbox"/> Farmer's Market <input type="checkbox"/> Marion Depot <input type="checkbox"/> Public Parking 7. Logan and Henderson <ul style="list-style-type: none"> <input type="checkbox"/> Farmer's Market <input type="checkbox"/> Marion Depot <input type="checkbox"/> Public Parking <input type="checkbox"/> Police Dept. <input type="checkbox"/> Post Office 8. Logan and Court <ul style="list-style-type: none"> <input type="checkbox"/> Marion Depot <input type="checkbox"/> Farmer's Market <input type="checkbox"/> Courthouse <input type="checkbox"/> MACA <input type="checkbox"/> Visitor Center | <p>Eastbound</p> <ol style="list-style-type: none"> 9. Court and Logan <ul style="list-style-type: none"> <input type="checkbox"/> City Hall <input type="checkbox"/> Courthouse <input type="checkbox"/> Community Building <input type="checkbox"/> Farmer's Market <input type="checkbox"/> Marion Depot <input type="checkbox"/> Public Parking 10. Court and Main <ul style="list-style-type: none"> <input type="checkbox"/> MACA <input type="checkbox"/> Post Office <input type="checkbox"/> Police Dept <input type="checkbox"/> City Hall <input type="checkbox"/> Community Building 11. West Henderson and Logan <ul style="list-style-type: none"> <input type="checkbox"/> Main Street <input type="checkbox"/> Marion Depot <input type="checkbox"/> Farmer's Market <input type="checkbox"/> Public Parking <input type="checkbox"/> Library <input type="checkbox"/> Fire Dept 12. Henderson and Main <ul style="list-style-type: none"> <input type="checkbox"/> City Hall <input type="checkbox"/> Courthouse <input type="checkbox"/> MACA <input type="checkbox"/> Police Dept. <input type="checkbox"/> Post Office <input type="checkbox"/> Public Parking <p>Westbound</p> <ol style="list-style-type: none"> 13. Court and Garden <ul style="list-style-type: none"> <input type="checkbox"/> Visitor Center <input type="checkbox"/> City Hall <input type="checkbox"/> Farmer's Market <input type="checkbox"/> Jury Parking 14. Court and Main <ul style="list-style-type: none"> <input type="checkbox"/> Library <input type="checkbox"/> Visitor's Center <input type="checkbox"/> Marion Depot <input type="checkbox"/> City Hall <input type="checkbox"/> Community Building 15. Court and Logan <ul style="list-style-type: none"> <input type="checkbox"/> Library <input type="checkbox"/> Rec Center <input type="checkbox"/> Visitor Center <input type="checkbox"/> Marion Depot <input type="checkbox"/> Farmer's Market <input type="checkbox"/> Public Parking |
|---|---|

Front Face Design



Rear Face Design

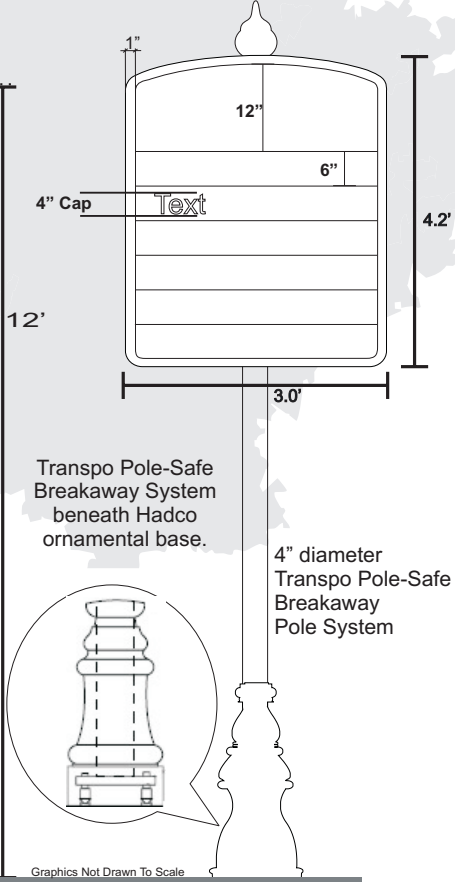

WAYFINDING SIGNAGE

SIGN DETAIL

Notes:

1. Signs shall be located on right side of roadway.
2. Shall be located a minimum of two feet (2') from the edge of roadway and four feet (4') from all pedestrian crosswalks.
3. All signs shall have a lateral offset distance of seven feet (7') from adjacent grade.
4. All lettering, messages, arrows, and other symbols shall be of an FHWA approved retroreflective material to show the same shape and color for both day and night optimal visibility.
5. All lettering shall be four inch (4") Helvetica font type in a combination of lower case letters with initial upper case letters with two inch (2") separation between lines with no more than six lines of text.
6. Sign structure shall utilize Transpo Pole-Safe omni-directional breakaway support system.

CAUTION! CONSISTENT AND ACCURATE COLOR REPRODUCTION IN THIS DOCUMENT CANNOT BE ASSURE DUE TO THE LIMITATIONS OF COLOR PRINTING TECHNOLOGY.

The Coated Patone Matching System is used for specifying signage color matches. (In the absence of actual sign material color chip reference set, actual specified product color swatches should be referenced for color matching.) Shown here are approximations of the primary signage background colors and supporting accent colors.

Actual color finishes on signage are to be matte or low luster (not shiny or glossy).

Fabricator is responsible for matching all colors and materials as indicated and is required to provide color and material samples for approval.

Street Identification Signs

“Street Name”

Sign Type F

These signs will replace the existing standard green street signs and will be incorporated on traffic poles and ten-foot (10') decorative black powder-coated poles where traffic poles are not installed to provide street orientation. The special color coding will help orient visitors that they are within the downtown. As they move out of the downtown they will be alerted that they have gone beyond the downtown because the street name signs will have reverted back to the standard green color.

Streets to be included are as follows:

NORTH/SOUTH
Main Street
Logan Street
Garden Street
Depot Street
New Street
Crawford Street
Railroad Street
Spring Street

EAST/WEST
Henderson Street
Court Street
Fort Street
State Street

Existing Street Signs

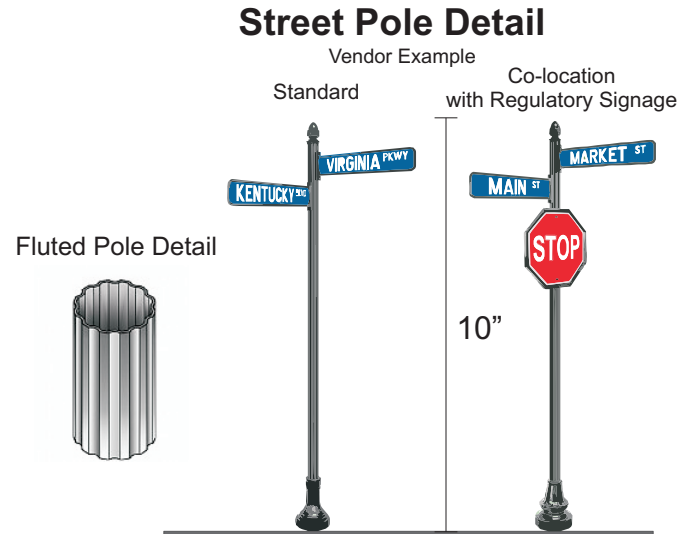

Traffic Pole Sign Placement

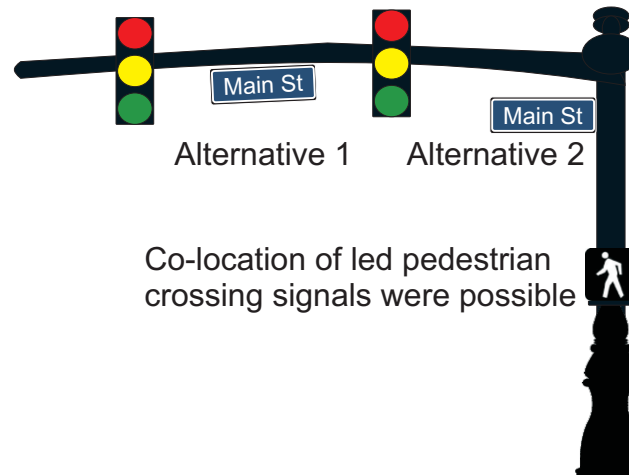

WAYFINDING SIGNAGE

SIGN DETAIL

Street sign pole
10 ft. fluted pole

Street Name Signs
12" x 42" with 6" letters

CAUTION! CONSISTENT AND ACCURATE COLOR REPRODUCTION IN THIS DOCUMENT CANNOT BE ASSURE DUE TO THE LIMITATIONS OF COLOR PRINTING TECHNOLOGY.

The Coated Patone Matching System is used for specifying signage color matches. (In the absence of actual sign material color chip reference set, actual specified product color swatches should be referenced for color matching.) Shown here are approximations of the primary signage background colors and supporting accent colors.

Actual color finishes on signage are to be matte or low luster (not shiny or glossy).

Fabricator is responsible for matching all colors and materials as indicated and is required to provide color and material samples for approval.

Pedestrian Kiosks

Sign Type H

The pedestrian kiosks are recommended in public parking areas and areas with high visibility and pedestrian traffic within the downtown area. This type of signage would provide a map of the downtown with key destinations including, but not limited to:

- Public Buildings
- Cultural Attractions
- Historic Buildings and Sites

Information may also include dates or information regarding annual events, festivals, or other recurring civic gatherings and celebrations.

In addition to free-standing kiosks, it is recommended that a community information board be installed in a central location within the downtown where, flyers, and notices can be displayed on a regular basis.

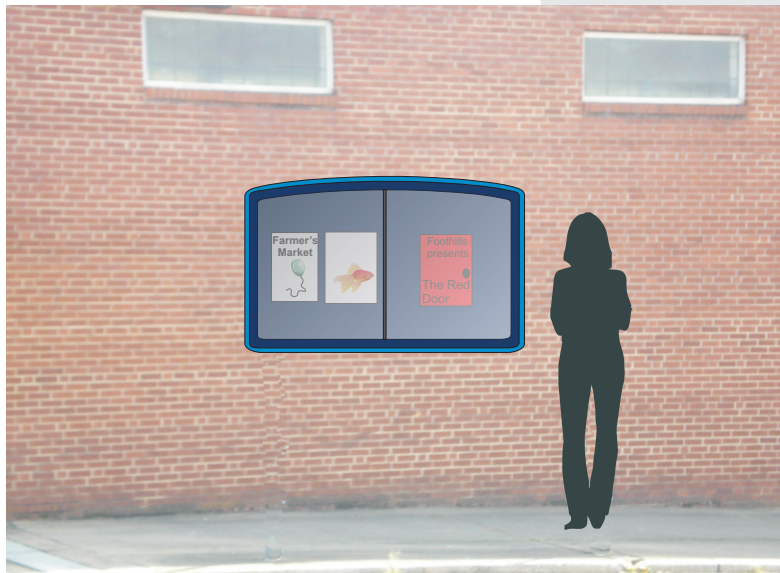

Wall Mounted Community Information Board

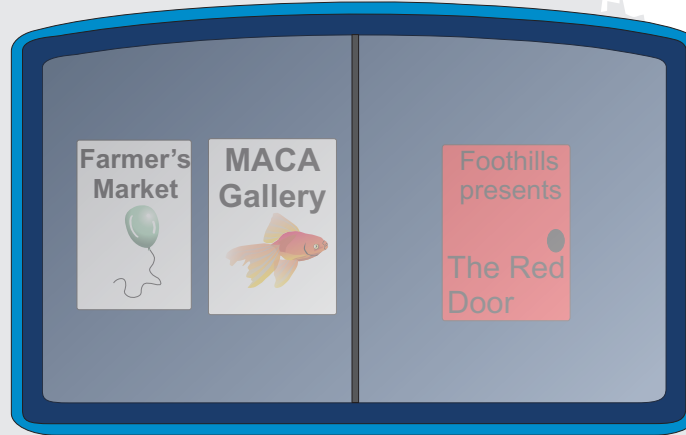

Freestanding Information Kiosk



WAYFINDING SIGNAGE

SIGN DETAIL

CAUTION! CONSISTENT AND ACCURATE COLOR REPRODUCTION IN THIS DOCUMENT CANNOT BE ASSURE DUE TO THE LIMITATIONS OF COLOR PRINTING TECHNOLOGY.

The Coated Patone Matching System is used for specifying signage color matches. (In the absence of actual sign material color chip reference set, actual specified product color swatches should be referenced for color matching.) Shown here are approximations of the primary signage background colors and supporting accent colors.

Actual color finishes on signage are to be matte or low luster (not shiny or glossy).

Fabricator is responsible for matching all colors and materials as indicated and is required to provide color and material samples for approval.

WI-FI SIGNAGE

Sign Type I

As part of the NC STEP program, the City installed free public wireless internet in the downtown as an amenity. To promote this initiative and create awareness for this service it is recommended that these signs be included in the wayfinding program, and be co-located where possible with other informational and regulatory signage. There are three design alternatives proposed, with the universal wireless internet symbol included in all three designs.

Design Option One



18"

12"

Design Option Two











Co-location Example



Co-location Example



Pantone Color Schedule

-  PANTONE DS 219-1C
-  PANTONE DS 5-1C
-  FOUNTAIN FILL RADIAL- 50
-  PANTONE DS 325-5C
-  PANTONE DS 325-9C
-  FOUNTAIN FILL LINEAR-22
-  PANTONE DS 265-5C
-  PANTONE DS 298-1C

Graphics



Universal Wi-Fi Symbol



City of Marion Seal



NC Rural Center Logol

Similar Examples:



WAYFINDING SIGNAGE

SIGN DETAIL

CAUTION! CONSISTENT AND ACCURATE COLOR REPRODUCTION IN THIS DOCUMENT CANNOT BE ASSURED DUE TO THE LIMITATIONS OF COLOR PRINTING TECHNOLOGY.

The Coated Pantone Matching System is used for specifying signage color matches. (In the absence of actual sign material color chip reference set, actual specified product color swatches should be referenced for color matching.) Shown here are approximations of the primary signage background colors and supporting accent colors.

Actual color finishes on signage are to be matte or low luster (not shiny or glossy).

Fabricator is responsible for matching all colors and materials as indicated and is required to provide color and material samples for approval.

Parking Directional & Identification Signs

Sign Type G

This type of sign will direct motorists to off-street public parking areas, and provide identification for those areas. These signs will replace those that are currently installed at each public parking lot within the downtown. These locations include:

- West Henderson Parking Lot
- Main Street Gazebo Parking Lot
- Logan Street & Henderson Street Parking Lot
- S. Main Street Parking Lot
- Garden Street Parking Lot (Jury Lot)

It should be noted that this plan does not make recommendations regarding regulations for type or length of use in off-street parking. However, given the current availability and supply of off-street parking it is recommended that policies be reviewed and changes be incorporated with the new signage to encourage more use of off-street parking areas.

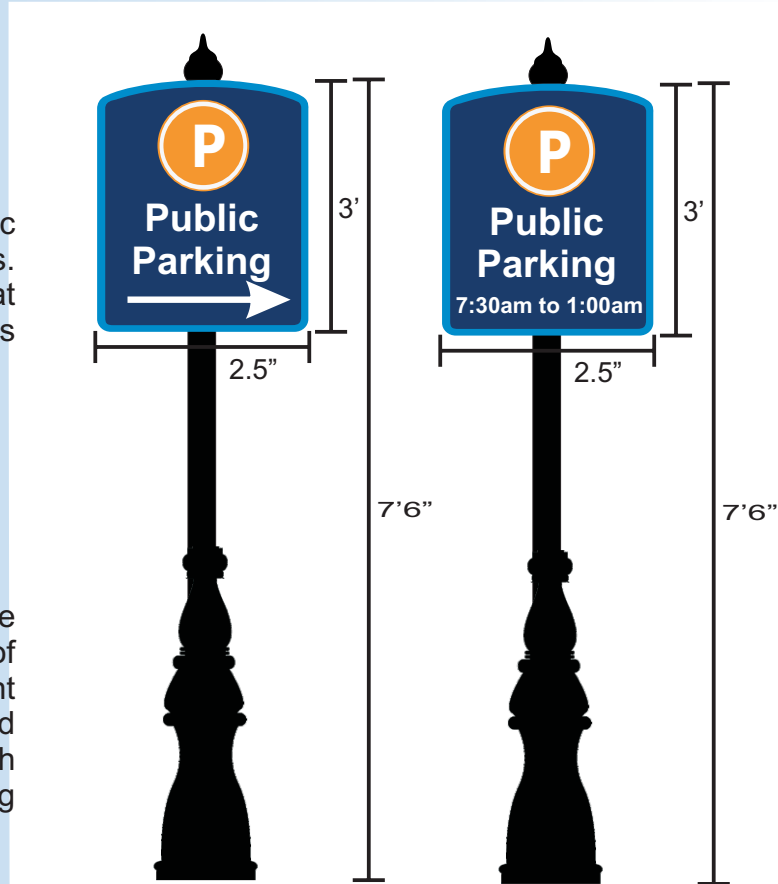

WAYFINDING SIGNAGE

SIGN DETAIL

CAUTION! CONSISTENT AND ACCURATE COLOR REPRODUCTION IN THIS DOCUMENT CANNOT BE ASSURE DUE TO THE LIMITATIONS OF COLOR PRINTING TECHNOLOGY.







The Coated Patone Matching System is used for specifying signage color matches. (In the absence of actual sign material color chip reference set, actual specified product color swatches should be referenced for color matching.) Shown here are approximations of the primary signage background colors and supporting accent colors.

Actual color finishes on signage are to be matte or low luster (not shiny or glossy).

Fabricator is responsible for matching all colors and materials as indicated and is required to provide color and material samples for approval.



Coated Pantone Matching System

	P1	Pantone DS 327-1 C
	P2	Pantone DS 201-1 C
	P3	Pantone DS 219-1 C
	P4	Pantone DS 226-2 C
	P5	Pantone DS 222-7 C
	P6	Pantone DS 325-9 C

Art

		
A1	A2	A3

Typography

Helvetica

AaBbCcDdEeFfGgHhIiJjFfLIMm
NnOoPpQqRrSsTtUuVvWwXxYyZz
1234567890







T1

Retroreflective Sheeting Material





All lettering, messages, arrows, and other symbols shall be of a FHWA approved retroreflective material to show the same shape and color for both day and night optimal visibility.

See attached for FHWA Retroreflective Sheeting Identification Guide for acceptable retroreflective materials.

Symbols

					
S1	S2	S3	S4	S5	S6

Arrows

			
North	South	East	West

WAYFINDING SIGNAGE

Symbols & Art

Notes:

1. Signs shall be located on right side of roadway.
2. Shall be located a minimum of two feet (2') from the edge of roadway and four feet (4') from all pedestrian crosswalks.
3. All signs shall have a lateral offset distance of seven feet (7') from adjacent grade.
4. All lettering, messages, arrows, and other symbols shall be of an FHWA approved retroreflective material to show the same shape and color for both day and night optimal visibility.
5. All lettering shall be four inch (4") Helvetica font type in a combination of lower case letters with initial upper case letters with two inch (2") separation between lines with no more than six lines of text.
6. Sign structure shall utilize Transpo Pole-Safe omni-directional breakaway support system.

CAUTION! CONSISTENT AND ACCURATE COLOR REPRODUCTION IN THIS DOCUMENT CANNOT BE

The Coated Patone Matching System is used for specifying signage color matches. (In the absence of actual sign material color chip reference set, actual specified product color swatches should be referenced for color matching.) Shown here are approximations of the primary signage background colors and supporting accent colors.

Actual color finishes on signage are to be matte or low luster (not shiny or glossy). Fabricator is responsible for matching all colors and materials as indicated and is required to provide color and material samples for approval.

Directional Sign Support System

This plan recommends the use of Transpo Pole-Safe omni-directional breakaway support system for all directional sign installations. According to the manufacturer, the primary component of the system is the high-strength coupling, designed to breakaway quickly and cleanly upon impact. Pole-Safe has been vehicle crash-tested in accordance with NCHRP report 350, and is approved for use on all FHWA projects. The following diagrams specific design details

1150 Series Wraparound Base (WAB1150) Specification Sheet

Project Name:	Location:	MFG: Phillips Haddco
Fixture Type:	Catalog No.:	City:

Ordering Guide

Example: WAB1150 3 A

Product Code	WAB1150	1150 Series Wraparound Base
Pole Diameter	3 4	3" 4"
Finish	A B G H J	Black White Vernis Bronze Green

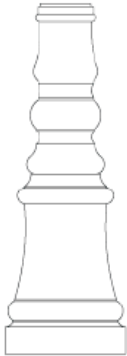

Specifications

HOUSING:
355 MPa high-strength, low-copper, proprietary cast aluminum alloy.

FINISH:
Thermoset polyester powdercoat is electrostatically applied after a five-stage conversion cleaning process and bonded by heat fusion thermosetting. Laboratory tested for superior weatherability and fade resistance in accordance with ASTM B-117-64 and ANSI/ASTM G63-77 specifications. For larger projects where a custom color is required, contact the factory for more information.

WARRANTY:
Three-year limited warranty.

Height:
29 3/4"

Base Diameter:
11"

Inside Diameter:
10 5/8"

For more information on proposed system see attached information sheet

Pole-Safe Series 5100 Breakaway Assembly

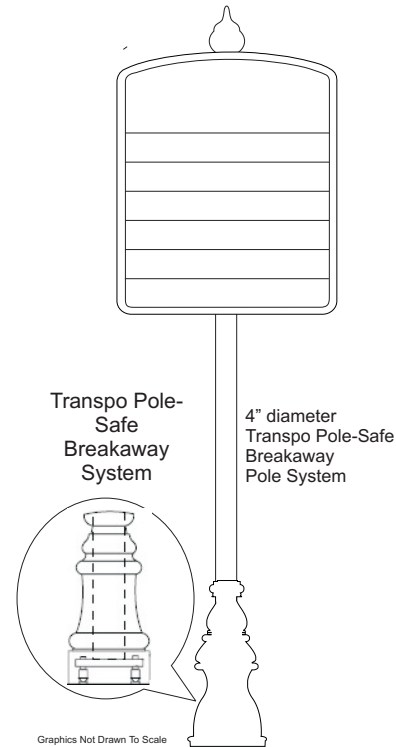
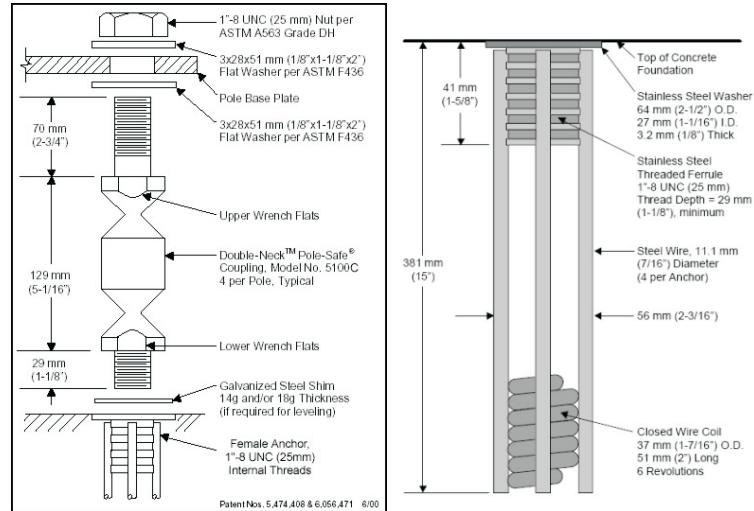

WAYFINDING SIGNAGE

SIGN DETAIL

Notes:

1. Signs shall be located on right side of roadway.
2. Shall be located a minimum of two feet (2') from the edge of roadway and four feet (4') from all pedestrian crosswalks.
3. All signs shall have a lateral offset distance of seven feet (7') from adjacent grade.
4. All lettering, messages, arrows, and other symbols shall be of an FHWA approved retroreflective material to show the same shape and color for both day and night optimal visibility.
5. All lettering shall be four inch (4") Helvetica font type in a combination of lower case letters with initial upper case letters with two inch (2") separation between lines with no more than six lines of text.
6. Sign structure shall utilize Transpo Pole-Safe omni-directional breakaway support system.

CAUTION! CONSISTENT AND ACCURATE COLOR REPRODUCTION IN THIS DOCUMENT CANNOT BE

The Coated Patone Matching System is used for specifying signage color matches. (In the absence of actual sign material color chip reference set, actual specified product color swatches should be referenced for color matching.) Shown here are approximations of the primary signage background colors and supporting accent colors.

Actual color finishes on signage are to be matte or low luster (not shiny or glossy). Fabricator is responsible for matching all colors and materials as indicated and is required to provide color and material samples for approval.

Directional Sign Site & Lateral Location for all Installations

This plan recommends that the placement of directional signs be placed consistent with the Manual on Uniform Control Devices. The following diagrams and site location details are minimum standards that will be followed to ensure compliance with all state and federal requirements.

Lateral Location For All Ground Mounted Directional Signs

The lateral installation shall exceed the minimum requirements of seven feet between the sidewalk grade and the lowest point of the sign face per MUTCD. All proposed directional signs shall have a lateral offset of seven and a half feet (7.5 ft.). The following diagram is an example of the MUTCD minimum lateral requirements.

Diagram: MUTCD Typical Lateral Off-Set

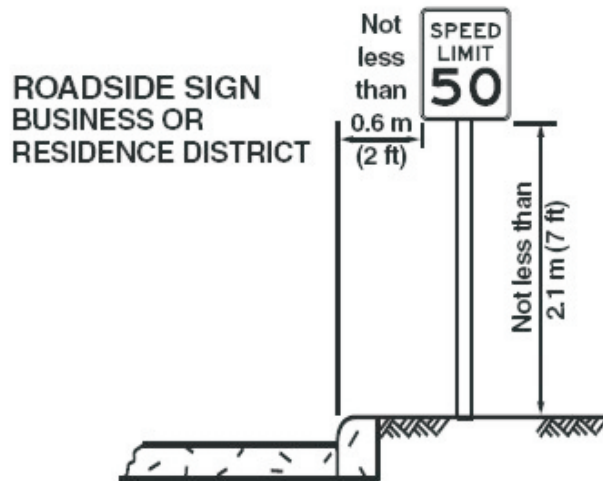

Not Drawn To Scale

Site Location For Urban Intersection

The placement of all directional signs to be installed on NC DOT designated roadways within the City of Marion's are within the Central Business District in downtown Marion and within a 25 mile hour speed limit zone. The minimum lateral offset from the edge of curb shall be two feet (2 ft.), and four feet (4ft) from all pedestrian crosswalks per the Federal Highway Administration (FHA) Manual on Uniform Traffic Control Devices (MUTCD) 2003 edition. The following figure is an example of the minimum standards per the FHAMUTCD Ed 2003, Part 2 Signs.

Diagram: MUTCD Typical Site Location of Proposed Directional Signs in an Urban Area

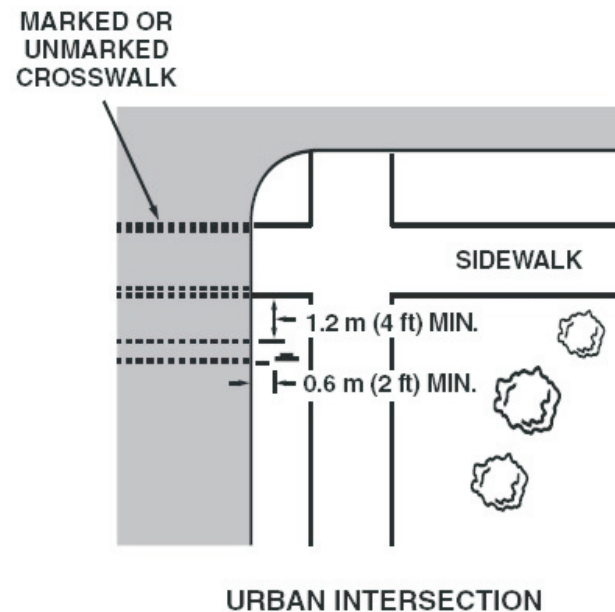

WAYFINDING SIGNAGE

SIGN DETAIL

Notes:

1. Signs shall be located on right side of roadway.
2. Shall be located a minimum of two feet (2') from the edge of roadway and four feet (4') from all pedestrian crosswalks.
3. All signs shall have a lateral offset distance of seven feet (7') from adjacent grade.
4. All lettering, messages, arrows, and other symbols shall be of an FHWA approved retroreflective material to show the same shape and color for both day and night optimal visibility.
5. All lettering shall be four inch (4") Helvetica font type in a combination of lower case letters with initial upper case letters with two inch (2") separation between lines with no more than six lines of text.
6. Sign structure shall utilize Transpo Pole-Safe omni-directional breakaway support system.

CAUTION! CONSISTENT AND ACCURATE COLOR REPRODUCTION IN THIS DOCUMENT CANNOT BE

The Coated Patone Matching System is used for specifying signage color matches. (In the absence of actual sign material color chip reference set, actual specified product color swatches should be referenced for color matching.) Shown here are approximations of the primary signage background colors and supporting accent colors.

Actual color finishes on signage are to be matte or low luster (not shiny or glossy). Fabricator is responsible for matching all colors and materials as indicated and is required to provide color and material samples for approval.